

6 5 4 3 2 1

**Basin Pipe Connections:**

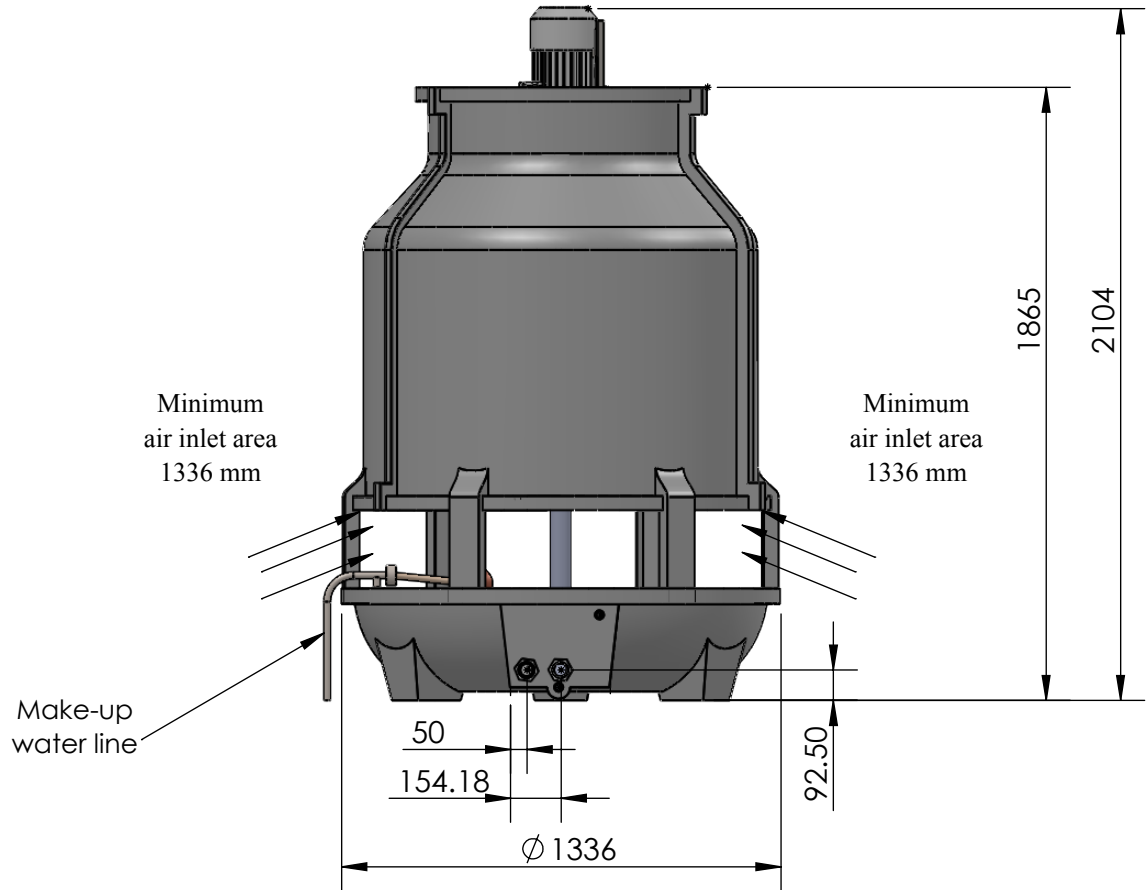
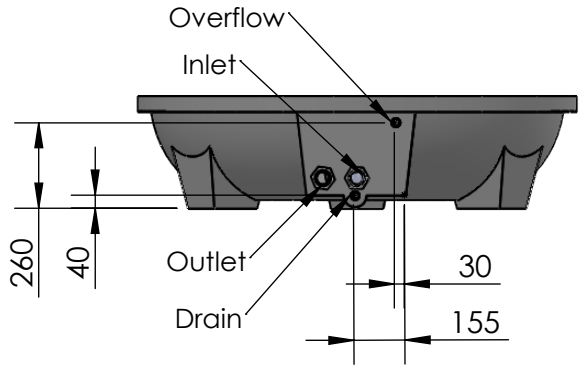

**REMARKS:**

**Piping Specification:**

- Water Inlet (WI) 38 mm
- Water Outlet (WO) 38 mm
- Over Flow (OF) 19 mm
- Make-UP (MU) 19 mm
- Drain (DN) 19 mm

**Weight:**

- Net Weight 102 Kg
- Operating Weight 260 Kg

All the measurements are provided in mm

UNLESS OTHERWISE SPECIFIED: DIMENSIONS ARE IN MILLIMETERS SURFACE FINISH: TOLERANCES: LINEAR: ANGULAR:			FINISH:		DEBURR AND BREAK SHARP EDGES		DO NOT SCALE DRAWING		REVISION: 01		
							TITLE: <b>Dimension Drawing (ART-20)</b>				
							 We come when Temperature matters <a href="http://www.artisan-craft.com">www.artisan-craft.com</a>				
			MATERIAL:		DWG NO.		DR-C-D-002		A4		
			WEIGHT:		SCALE: 1:23		SHEET 1 OF 1				

	NAME	SIGNATURE	DATE		
DRAWN	Mahmuda		24/02/18		
CHK'D	Shahed		24/02/18		
APPVD	Shahed		24/02/18		
MFG					
Q.A					

6 5 4 3 2 1

D

D

C

C

B

B

A

A