

6 5 4 3 2 1

**Basin Pipe Connections:**

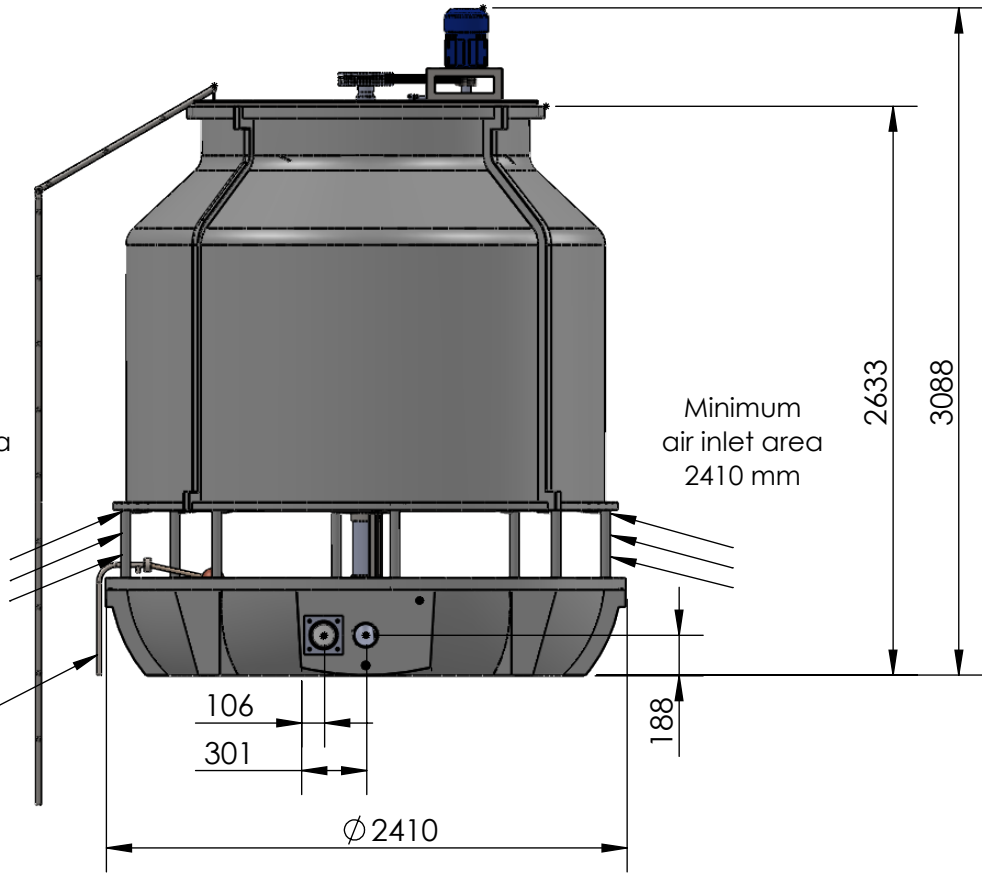
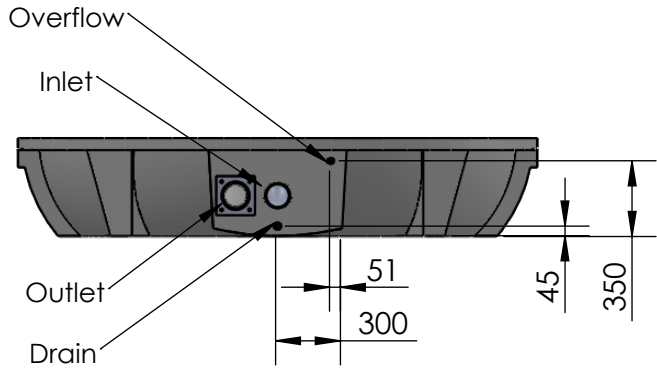

**REMARKS:**

**Design Specification:**

- Water Inlet (WI) 100 mm
- Water Outlet (WO) 100 mm
- Over Flow (OF) 19 mm
- Make-Up (MU) 19 mm
- Drain (DN) 25 mm

**Weight:**

- Net Weight 510 Kg
- Operational Weight 1340 Kg

Ladder Height 3328 mm considering base 600 mm  
Customer may extend ladder as per their need.

All the measurements are provided in mm.

UNLESS OTHERWISE SPECIFIED: DIMENSIONS ARE IN MILLIMETERS SURFACE FINISH: TOLERANCES: LINEAR: ANGULAR:			FINISH:		DEBURR AND BREAK SHARP EDGES		DO NOT SCALE DRAWING		REVISION			
							TITLE: <b>Dimension Drawing (ART-100)</b>					
												
												DWG NO. <b>DR-C-D-006</b>
							WEIGHT:		SCALE:1:35		SHEET 1 OF 1	

	NAME	SIGNATURE	DATE			
DRAWN	Mahmuda		26/02/18			
CHK'D	Shahed		26/02/18			
APPVD	Shahed		26/02/18			
MFG						
Q.A						

6 5 4 3 2 1

D

D

C

C

B

B

A

A