

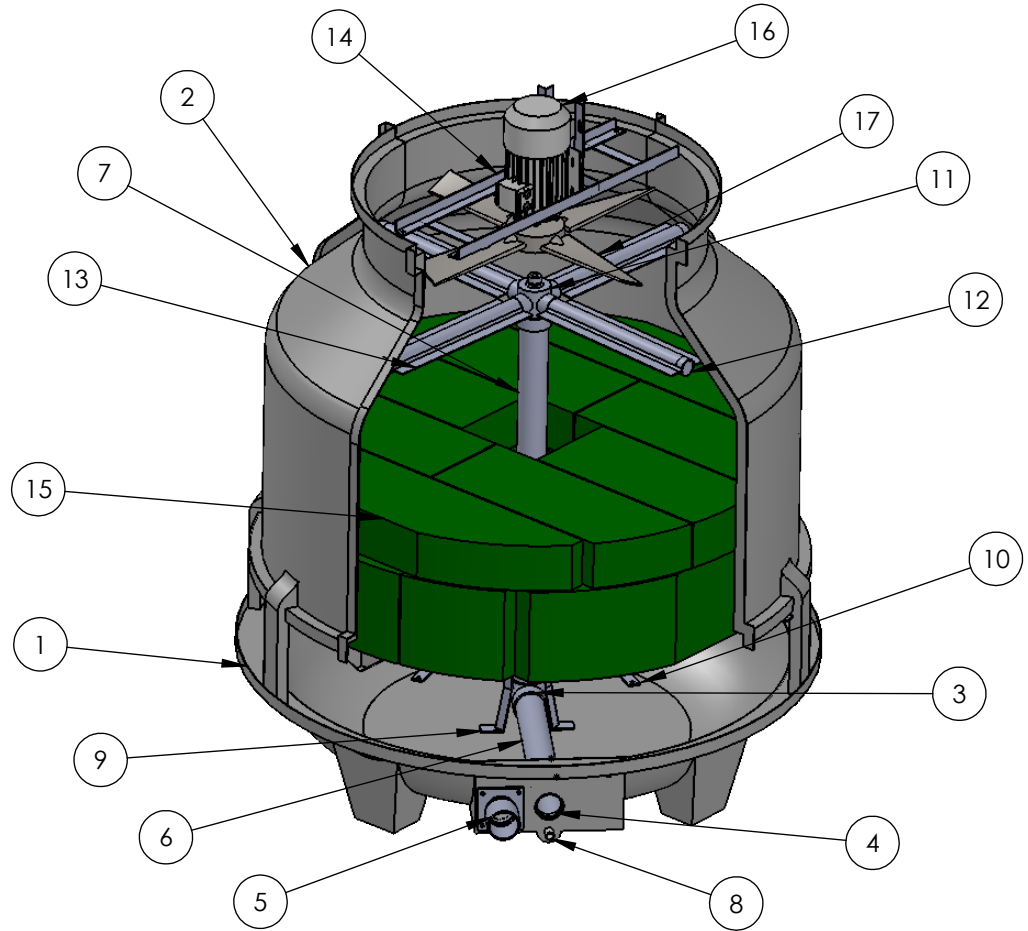

6 5 4 3 2 1

ITEM NO.	PART NAME	QTY.
1	Basin	1
2	Casing	4
3	Elbow	1
4	Inlet	1
5	Outlet	1
6	Horizontal pipe	1
7	Vertical pipe	1
8	Tank Connector Drain	1
9	Hub support stand	1
10	Fill support pipe radial	8
11	Sprinkler head	1
12	Distribution pipe	4
13	Drift Eliminator	4
14	Fan Base	1
15	Infill	16
16	Motor	1
17	Fan	1



UNLESS OTHERWISE SPECIFIED: DIMENSIONS ARE IN MILLIMETERS SURFACE FINISH: TOLERANCES: LINEAR: ANGULAR:			FINISH:		DEBURR AND BREAK SHARP EDGES		DO NOT SCALE DRAWING		REVISION					
							TITLE: <b>Assembly Drawing (ART-50)</b>							
							 <p><b>Artisan Craft (Bd) Ltd.</b> We come when Temperature matters www.artisan-craft.com</p>							
DRAWN by		Mahmuda		SIGNATURE		DATE						25/02/18		
CHK'D by		Shahed		SIGNATURE		DATE						25/02/18		
APPV'D by		Shahed		SIGNATURE		DATE		25/02/18						
							MATERIAL:		DWG NO.		A4			
							FRP, MS, PVC		DR-C-A-004					
							WEIGHT:		SCALE:1:23		SHEET 1 OF 1			

6 5 4 3 2 1

D

D

C

C

B

B

A

A