

D

C

B

A

6

5

4

3

2

1

ITEM NO.	PART NAME	QTY.
1	Casing	4
2	Elbow	1
3	Horizontal pipe	1
4	Vertical pipe	1
5	Sprinkler head	1
6	Inlet	1
7	Outlet	1
8	Tank Connector Drain	1
9	Hub support stand	1
10	Fill support radial	8
11	Drift Eliminator	4
12	Fan base	1
13	Distribution Pipe	4
14	Basin	1
15	Infill	16
16	Motor	1
17	Fan	1

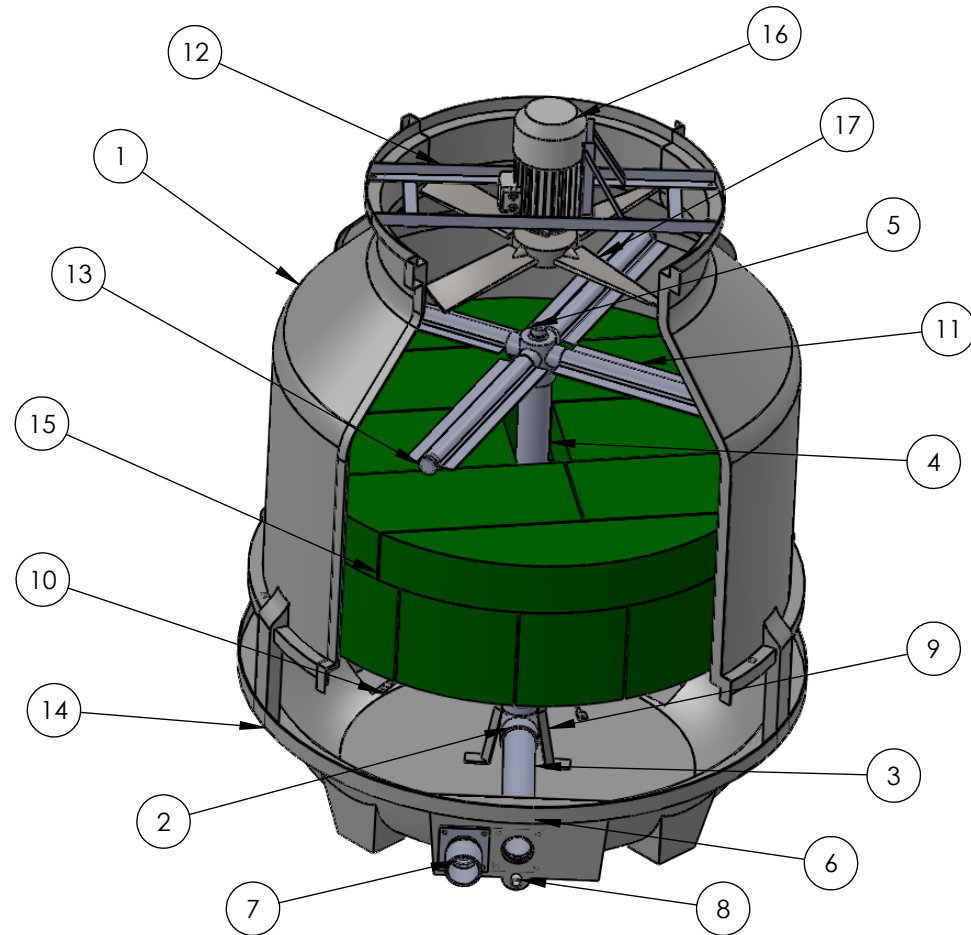

D

C

B

A

UNLESS OTHERWISE SPECIFIED: DIMENSIONS ARE IN MILLIMETERS SURFACE FINISH: TOLERANCES: LINEAR: ANGULAR:				FINISH:		DEBURR AND BREAK SHARP EDGES		DO NOT SCALE DRAWING		REVISION					
								TITLE: Assembly Drawing (ART-30)							
								 Artisan Craft (Bd) Ltd. We come when Temperature matters www.artisan-craft.com							
DRAWN by		Mahmuda		SIGNATURE		DATE						25/02/18		DWG NO.	
CHK'D by		Shahed		SIGNATURE		DATE		25/02/18		MATERIAL:		FRP, MS, PVC		SCALE:1:21	
APPV'D by		Shahed		SIGNATURE		DATE		25/02/18		WEIGHT:		SHEET 1 OF 1			

6

5

4

3

2

1