

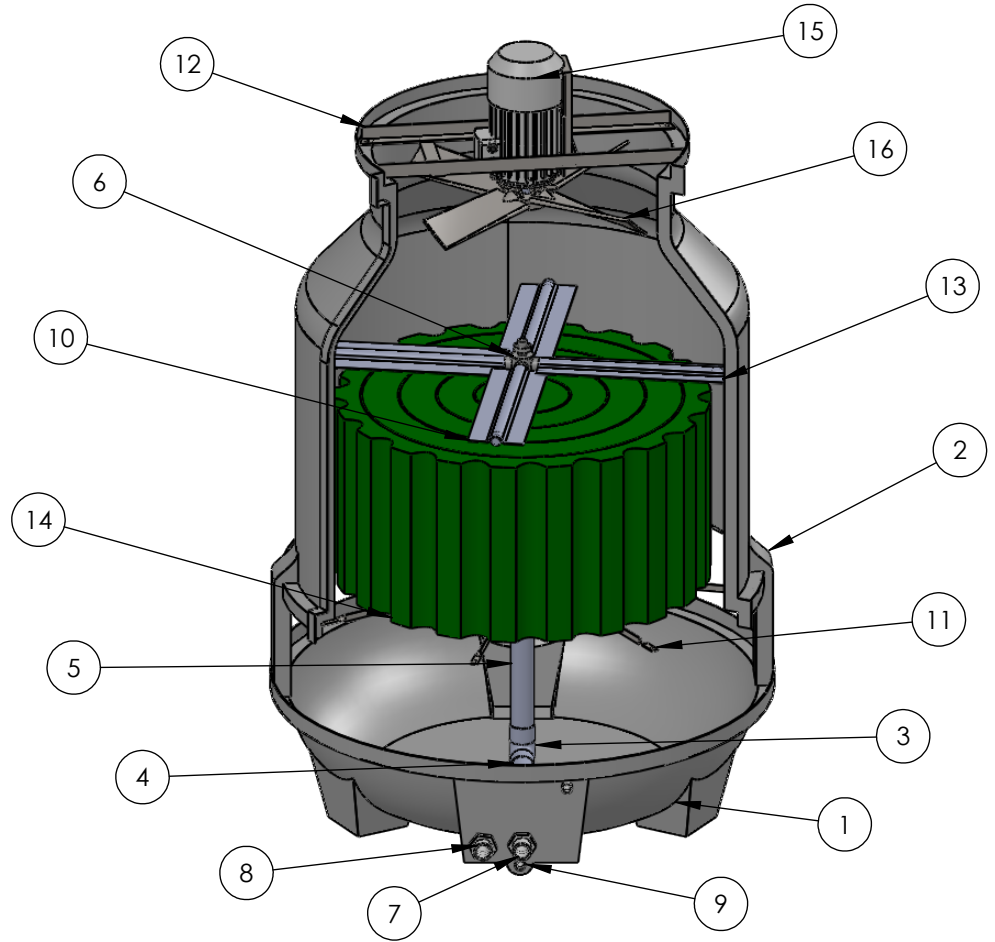

6 5 4 3 2 1

ITEM NO.	PART NAME	QTY.
1	Basin	1
2	Casing	3
3	Elbow	1
4	Horizontal pipe	1
5	vertical pipe	1
6	Sprinkler head	1
7	Tank Connector Inlet	1
8	Tank Connector Outlet	1
9	Tank Connector Drain	2
10	Drift Eliminator	4
11	Fill support radial	8
12	Fan base	1
13	Distribution Pipe	4
14	Infill	Roll
15	Motor	1
16	Fan	4



6 5 4 3 2 1

UNLESS OTHERWISE SPECIFIED: DIMENSIONS ARE IN MILLIMETERS SURFACE FINISH: TOLERANCES: LINEAR: ANGULAR:			FINISH:		DEBURR AND BREAK SHARP EDGES		DO NOT SCALE DRAWING		REVISION						
							TITLE: Assembly Drawing (ART-20)								
							 <p>Artisan Craft (Bd) Ltd. We come when Temperature matters www.artisan-craft.com</p>								
DRAWN by		NAME		SIGNATURE		DATE						DWG NO.		A4	
CHK'D by		NAME		SIGNATURE		DATE						DR-C-A-002			
APPV'D by		NAME		SIGNATURE		DATE		MATERIAL:		SCALE:1:20					
								FRP, MS, PVC		SHEET 1 OF 1					
								WEIGHT:							

D

D

C

C

B

B

A

A