

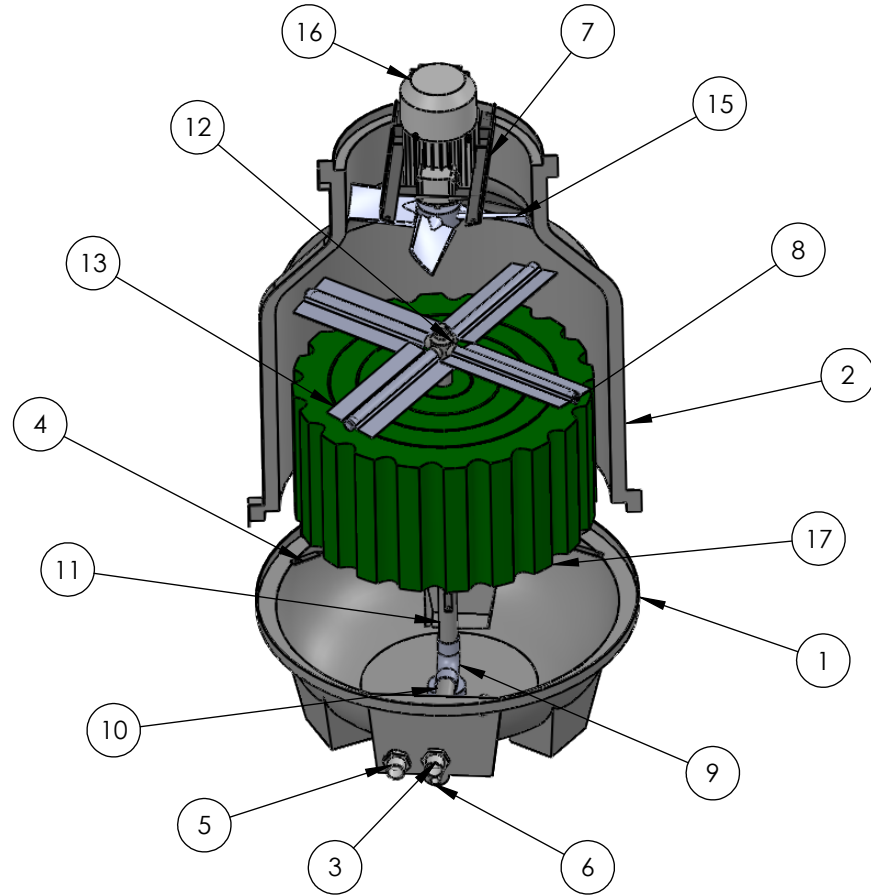

6 5 4 3 2 1

ITEM NO.	PART NAME	QTY.
1	Basin	1
2	Casing	2
3	Tank Connector Inlet	1
4	Fill Support Radial Bar	6
5	Tank Connector Outlet	1
6	Tank Connector Drain	2
7	Fan base	1
8	Distribution pipe	4
9	Elbow	1
10	Horizontal pipe	1
11	Vertical pipe	1
12	Sprinkler head	1
13	Drift Eliminator	4
15	Fan	1
16	Motor	1
17	Infill	Roll



UNLESS OTHERWISE SPECIFIED: DIMENSIONS ARE IN MILLIMETERS SURFACE FINISH: TOLERANCES: LINEAR: ANGULAR:			FINISH:		DEBURR AND BREAK SHARP EDGES		DO NOT SCALE DRAWING		REVISION				
							TITLE: Assembly Drawing (ART-10)						
							 <p>Artisan Craft (Bd) Ltd. We come when Temperature matters www.artisan-craft.com</p>						
			MATERIAL:		DWG NO.							A4	
			FRP, MS, PVC		DR-C-A-001								
							WEIGHT:		SCALE:1:20		SHEET 1 OF 1		

6 5 4 3 2 1

D

D

C

C

B

B

A

A